

Smooth Roll Advantage Side Dump

Installation, Maintenance and Safety Instructions



Sioux City Tarp
5201 Harbor Drive
Sioux City, IA 51111
Ph: 712-258-6939

Getting Started

Important: Please read manual thoroughly and completely. This manual explains how to install, operate & maintain the Smooth Roll Advantage Systems safely.

Warnings, cautions, notes, & hints: This manual is available for your safety & assistance while installing your new Smooth Roll Advantage system. There are two levels of steps found in this installation manual. The primary steps are found in **BOLD AND ALL CAPITAL LETTERS**. Followed by secondary steps in regular font.

Type of systems ordered:

There are two types of tarping styles. One is having the tarp inside the tub; you can have either mesh, vinyl, or ballistic tarp material with this style of tarping. The second is having the tarp stay on the bulkhead of the trailer. Some have a large bulkhead so that you will not need to have an extension for it. Others will need an extension from the factory to allow the tarp ride on the bulkhead properly. The tarp can be mesh, vinyl, or ballistic as well.

Step 1

INSTALLATION OF FIXED SIDE TARP MOUNTING BRACKETS

PARTS NEEDED:

Fixed Side Tarp Mounting Bracket 2071 (7)

Hinge Weldment 2088 (2)



Part #2088

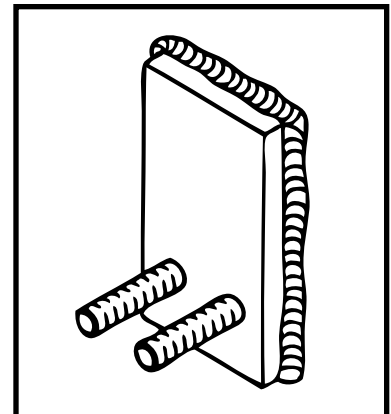

Part #2071

***Note:** Some trailers may already have these on the trailer. If so, check that all stops are in good condition. If any studs are broken off on fixed side tarp mounting bracket, please replace. This is what maintains your tarp security and in place when moving the tarp from open to close positions. (per the hinge weldment). If all are ok, please proceed to STEP 2.

1 - To achieve proper spacing of the fixed side tarp mounting brackets, place all the brackets on passenger side of the trailer. To mark for the front and rear brackets, mark them 4" in from the tub and 4" down from the bottom of the side rail using part number 2071. Then, looking at tub left to right place a second weldment 3" in and 4" down for extra support for tension on front and rear of the tub. **SEE FIGURE 1.1**

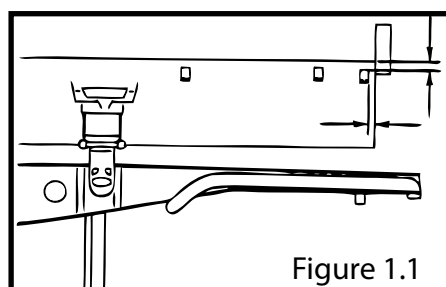

Figure 1.1

Step 1, cont.

- 2 - Measure and spread out the remainder of the mounting brackets evenly. Part numbers 2071 and 2088.
**Note: Refer to FIGURE 1.1 for proper order of all brackets. Part number 2088 is to be measured 5" down from the bottom of the side rail to keep all clamps even.*
- 3 - Remove all paint and dirt that will cause bad welds to be made on the tub of the trailer and have a good ground for all (9) of the tarp mounting plates.
- 4 - Weld all plates in place.
- 5 - Prime and paint all brackets when cooled with tub color.

Step 2

INSTALLING THE TARP MOUNTING BRACKETS (UNIVERSAL):

PARTS NEEDED:

- Tarp Mounting Bracket (Universal) 2094 (2)
- Tarp Mounting Bracket Weldment (4)
- ½" x 1- 1/8" cap screws (8)
- ½" Nylon lock nuts (8)
- ½" Flat washer (8)

**Note: The placement of the Tarp Mounting Bracket (Universal) are very important for safety and optimal performance of the Smooth Roll Advantage System.*

- 1 - Assemble the swing arm clamp and the tarp mounting bracket with a vice or a pair of vice grips. Then drill the four ½" holes in the tarp mounting brackets. Use the bolts, washers and nuts provided.
- 2 - Put the assembly on the end of the tub and place it 5 ½" below the tube side rail. Center with the cylinder and side-to-side. Make sure that the bracket is level with the trailer. Once it is level, mark, grind and remove all dirt for welding of the mounts on good ground. **SEE FIGURE 2.1**
- 3 - Weld assembly on to the trailer
- 4 - Prime and paint the brackets to match tub.
- 5 - Repeat on opposite end of the tub.

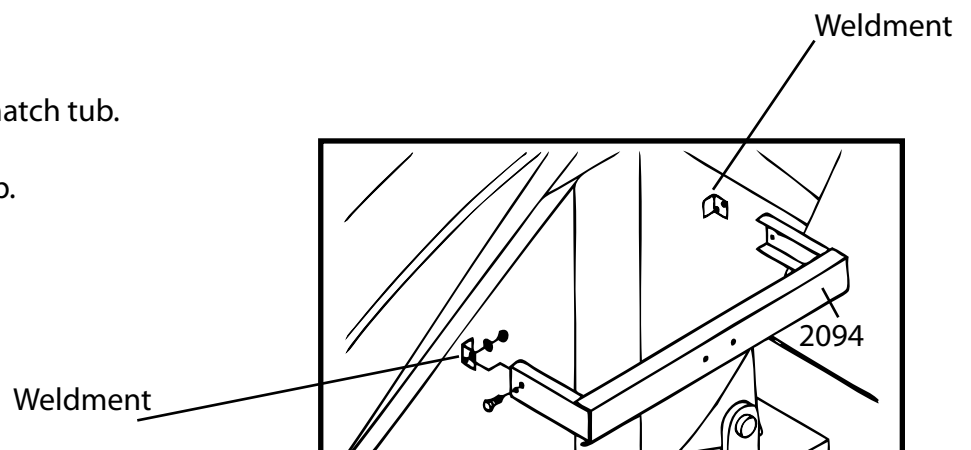

Figure 2.1

Step 3

INSTALLATION OF SPRING MOUNTING BRACKET

PARTS NEEDED:

Front Mounting Plate 2054
Rear Mounting Plate 2055
Front Pivot Plate 2069
Rear Pivot Plate 2070
5/16" Nylon Lock Nut (8)
1/2" Nylon Lock Nut (4)
1/2" Flat Washer (4)

1- The back of the mounting plates are labeled front and rear. When installing onto the tarp mounting bracket, favor the studs on the back of the mounting plates towards the bottom of the tarp mounting bracket when looking at the face of the plate. The bar should be to the passenger side of the trailer. **SEE FIGURE 3.1**



Figure 3.1

2 - Place the studs in the perforated holes and lock down with 1/2" flat washers and lock nuts.

3 - Repeat on other side of trailer.

**Note: Front mounting, rear mounting and pivot plates are already put together with 5/16" nylon lock nuts when full kit is ordered.*

Step 4

INSTALLATION OF FRONT AND REAR ARM ASSEMBLIES

PARTS NEEDED:

Front Spring 2052
Rear Spring 2053
Front arm assembly, Straight or Offset 2048/2050
Rear arm assembly, Straight or Offset 2049/2051
1" flat washer (2)
5/16 cotter pin

1 - Place front spring on the front pivot plate and place the 90 degree bent tab on the bar toward the passenger side of the tub.

2 - Pick up the front arm assembly, then slide the base of the arm assembly onto the shaft.

***WARNING: MAKE SURE YOU HAVE FIRM AND STURDY GROUND WHEN PLACING ASSEMBLY INTO PLACE. FAILURE TO DO SO MAY CAUSE INJURY TO YOURSELF OR TO THE SMOOTH ROLL ADVANTAGE SYSTEM.**

Step 4, cont.

- 3 - Once arm assembly is slid into place, place the flat washer on and follow it with the cotter pin. Spread the pin at the front this time. Then place it in the relax position on the trailer.
- 4 - Repeat on the other side, however; do not spread the cotter pin on the rear.

Step 5

MEASURE FOR THE ROLL TUBE AND STATIONARY TUBE

- 1 - Once you have the front and rear arm assemblies installed, place the front and rear gear boxes on a sturdy surface and measure from front to rear of the roll tube. **SEE FIGURE 5.1**
- 2 - Place the roll tube on the ground and slide the pre-welded insert on one end of the roll into the other roll tube and weld the tube together. **Note: Before welding, make sure the tube is lying straight. Avoiding this will cause strain on the Smooth Roll Advantage System.*
- 3 - Once welded on each side of the weld that connects the two pieces together, make three marks 3" apart on each side of the weld (for a total of 6). Then drill 1/4" holes in the tubes and install 3/4" long rivets. Then rotate the welded tubes 180 degrees and mark and drill 6 more 1/4" holes, (3" apart) and install 6 more 3/4" long rivets in the holes. **SEE FIGURE 5.2**
- 4 - Next, cut the roll tube to length and slide, then set aside until stationary tube is cut.
- 5 - To measure for the stationary tube, determine if your tarp is on the body or on the header of the trailer. If on header, measure full length of tub. In the tub, measure full tub to determine length.
- 6 - Make the stationary tube assembly by placing the two 1 1/4" galvanized tubes together and weld.
- 7 - Cut tube to length and set aside.
- 8 - Spread out the tarp on a flat service.
- 9 - Insert the stationary tube and keep it flush on the front and put in a 3/4" self-tapping screw with a flat washer in the hem of the tarp. Walk to the back of the tarp and put a stretch on the tarp so all of the wrinkles are out and place the other 3/4" screw and washer in the hem.
10. Insert roll tube into the tarp and balance the tube so that it is sticking out equally on each side of the tarp. Do not place U-Clamps on the tarp at this time.

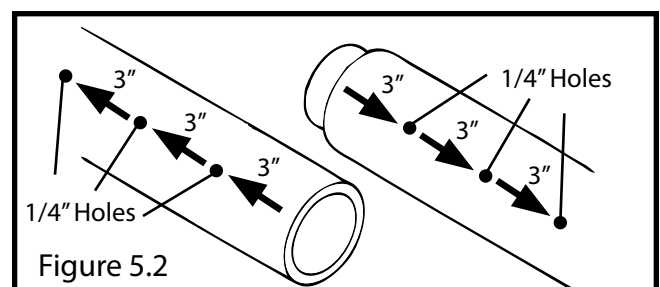
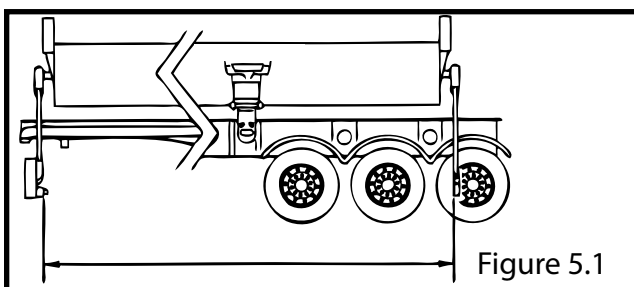

Step 6

INSTALLING TARP ASSEMBLY

PARTS NEEDED:

Tarp assembly (1)
Tarp cradle 2068 (2)
Tarp Clatch 2072 (7)
5/16" flange nut (14)
3 3/8" (2)
3/8" nylon lock nut (2)

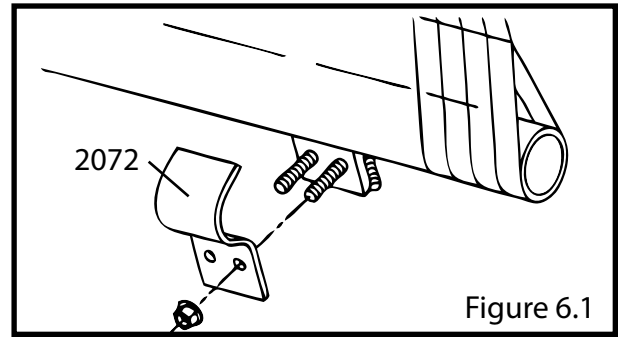

1 - Lift the tarp assembly onto the headers of the trailer then place the roll tube in the center of the header. Secure with clamps or people holding.

***WARNING: FAILURE TO SECURE THE ROLL TUBE ON EACH END OF THE TRAILER MAY CAUSE SERIOUS INJURY OR DEATH.**

2 - Center the tarp on the header where you want the tarp to ride in the tub or on header.

3 - Unroll the tarp so that the stationary tube comes into position for securing the tarp on the stationary side of the trailer.

4 - Secure the stationary tube to the tarp clatches with 5/16" flange nuts and tarp cradles with 3"x3/8" bolts and nyloc nuts. **SEE FIGURES 6.1**

5 - Once all the tarp clatches and tarp cradles are secure, roll the roll tube over to the other side of the trailer.

Step 7

MOUNTING THE TARP SYSTEM

***WARNING: MAKE SURE TO HAVE GOOD FOOTING. SOME OF THE STEPS MAY REQUIRE TWO PEOPLE. THERE ARE AWKWARD AND SENSITIVE STEPS AND SOME HELP MAY BE REQUIRED. FAILURE TO DO SO CAN CAUSE INJURY TO YOURSELF AND/OR THE SMOOTH ROLL ADVANTAGE SYSTEM.**

PARTS NEEDED:

U-Clamps 2085 (18)	1/2" x 2" Bolts (4)
3/4" Self Tapping Screws (18)	1/2" Flat Washer 2098 (8)
Rubber Wheels 2074 (2)	1/2" Locknuts (4)
Traction Sleeve 2073 (2)	Tub Top Cradle 2082 (2)
3/4" x 1/4" Steel rivets (12)	Hinge Weldment 2088 (2) - on roll side
1 1/4" 8mm Self Tapping Screws (6)	
Tork Screws (4)	
Tarp Cradle 2068 (2) - on roll side	
Large Washers (4)	
Hockey Stick 2096 (2)	
Hockey Stick Back Plate 2097 (2) - on roll side	

Step 7, cont.

1. Slide the rubber wheels on front end of the tube so that it touches the tarp.

**Note: Do not put screws in yet. You may have to make adjustments.*

2 - Lift the front arm assembly and insert roll tube onto the shaft of the arm assembly. Bring it flush with inside of the shaft and keep arm parallel with the trailer.

3 - Go to the rear of the trailer and slide on the rubber wheel on end of roll tube as done on the front of the trailer.

4 - After installing the rear arm assembly onto the mounting pivot plates, put on the flat washer and insert cotter pin and spread the pin.

5 - Double check that the front and rear arms are parallel with the tub. Once parallel, measure from the end of the aluminum tube and place three marks at 2 1/2", 5" and 7 1/2". Then drill a 1/4" hole at the 2 1/2" mark into the tube and through the insert. Install a 1/4" rivet in the drilled hole. Then proceed to drill 1/4" holes at the 5" and 7 1/2" marks and install the 1/4" rivets. Then rotate the tube 180 degrees and measure and mark at 2 1/2", 5" and 7 1/2". Then drill all 3 holes with 1/4" bit and install three 1/4" rivets. **SEE FIGURE 7.1**

6 - Now that the arms are secure on the roll tube, make sure that the tarp is even on the trailer having the same amount of space on the front and back of the trailer.

7 - Starting on the front of the trailer, drill the first U-Clamp and Self-tapping screw on the hem of the tarp. Place two U-Clamps and screw on the hem, one on each piece of strapping. Go to the rear of the trailer and pull all the wrinkles you can out of the tarp. Place two more U-Clamps and screws just like you have done on the front of the trailer. Put the remaining U-Clamps and screws on each seam and where there is twin belting down the rest of the tarp.

**Note: Keep all the U-Clamps in a straight line. This will keep equal tension on the tarp. If tension is not right on the tarp, then the tarp may wear out faster.*

8 - **Setting the rubber wheels:** The rubber wheels should be placed next to the tarp so that they don't interfere with the lock down of the Smooth Roll Advantage System. **SEE FIGURE 7.2** then drill one hole in the center of the wheel and put in the tork screw. Do the same on the opposite side of the wheel

9 - Repeat on the rear of the trailer.

10 - **Installing the roll tube protectors:** It can be done by marking where the header of the trailer will rub the tube or once the wiring is done, roll over your Smooth Roll Advantage System and see exactly where the header does rub on the tube to see where it needs to be protected.



Figure 7.1



Figure 7.2

Step 7, cont.

11 - Put in the three 1 ¼" self tapping screws into the roll tube protector.

12 - Repeat on the other side of the trailer.

13 - Install the tarp cradles on the roll side of the trailer.

**Note: There are two separate instruction depending on the style you wish for the tarp to stay when in the "closed position."*

14 - If the tarp is to fasten down on the top of the tube, your trailer should have studs already. If not, you will have to weld them onto the trailer. Then fasten the tub top cradles (Part #2082) to the studs on the top of the tub, roll the tarp to where you want the tarp to stop and place your hook against the roll tube. Mark where it will set and roll the tarp out of the way. Grind off all the dirt and paint out of the weld area and proceed to weld the cradle into place. Repeat on opposite end of the trailer.

15 - **For the tarp cradles on tarp lock down under the side rail of the tub:** Roll the tarp to the closed position and place the cradles into place on the front of the tub with the bolt washers and hockey stick back plate provided.

**NOTE: THE BACK MAY BE HIGHER ON THE BACK OF THE TUB. THIS IS DUE TO THE WEIGHT DIFFERENCE ON THE FRONT AND REAR ARM OF THE MOTOR GEAR BOXES AND ACCESSORIES ON THE FRONT OF THE TRAILER. TO TAKE CARE OF THIS ANGLE, THE CRADLE ON THE BACK TILTED DOWN MORE THAN THE BACK. THIS WILL CORRECT THE PROBLEM FOR FURTHER DETAILS IN THE TROUBLE SHOOTING, SEE THE BACK TO THIS BOOK.*

19 - If your tub is not made with the proper holes, than you will need to weld these onto your trailer. Only tack the cradles on the tub and run it open and closed. Do this to make sure that they are in the proper place and the roll tube clears these when it is moving to the open position and into the closed position.

Now you have installed your Smooth Roll Advantage System. We hope you enjoy it and come back for all your tarping needs. Thank you for your purchase of our Smooth Roll Advantage System. If you have any questions, please see the trouble shooting section on the back of this book. Also, feel free to call us any time during business hours and we will be glad to help with your questions.



Sioux City Tarp
5201 Harbor Drive
Sioux City, IA 51111
Ph: 712-258-6939

Parts Listing



2048 - Complete Front Offset Arm Assembly



2049- Complete Rear Offset Arm Assembly



2050- Complete Front Straight Arm Assembly



2051- Complete Rear Straight Arm Assembly



2052 & 2053- Front & Rear Springs

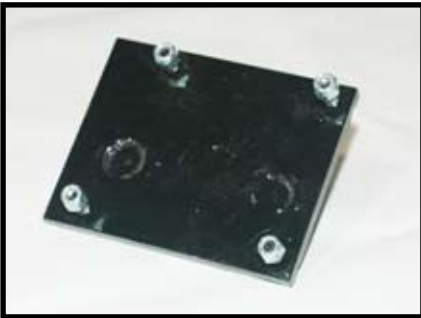

2054 - Front Mounting Plate



2055 - Rear Mounting Plate



2065 - Switch Kit



2068 -Tarp Cradle



2069 & 2070 - Front & Rear Pivot Plate



2071 - Fixed Side Tarp Mounting Bracket



2073 - Traction Sleeve



2074 - Rubber Wheel



2082 - Tub Top Cradle

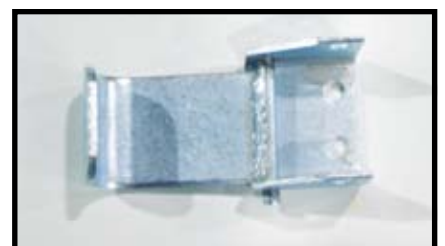

2088 - Hinge Weldment

Parts Listing



2089 - Front Motor Gear Box



2090 - Rear Motor Gear Box



2094 - Tarp Mounting Bracket
(Universal)



2093 - Female Socket
Mounting Bracket



2095 - Pigtail Vertical/Horizontal
Electrical Cord



2096 - Hockey Stick



2097 - Hockey
Stick Back Plate



2101 - Solenoid for
Switch

Smooth Roll Parts	Part #	\$
Complete Front Offset Arm Assembly	2048	775.00
Complete Rear Offset Arm Assembly	2049	595.00
Complete Front Straight Arm Assembly	2050	675.00
Complete Rear Straight Arm Assembly	2051	495.00
Front Spring	2052	112.10
Rear Spring	2053	112.10
Front Mounting Plate	2054	26.75
Rear Mounting Plate	2055	26.75
Fixed Tube 1-1/8" x 24' with connector	2060	47.45
Complete Rolltube	2061	380.00
Roll Tube 3 1/2" x 20' with connector	2062	228.00
Roll Tube 3 1/2" x 20' no connector	2063	182.00
Roll Tube Splice	2064	28.80
Switch Kit	2065	197.00
Straight Arm Plate & Alum. Arm Front & Rear	2066	150.00
Offset Arm Plate & Alum. Arm Front & Rear	2067	150.00
Tarp Cradle	2068	21.70
Front Pivot Plate	2069	161.10
Rear Pivot Plate	2070	161.10
Fixed Side Tarp Mounting Bracket	2071	7.75
Tarp Clatch (holds 1 1/8" tube)	2072	7.75
Traction Sleeve	2073	22.20
Rubber Wheel	2074	32.07
Arm Power Cord	2081	101.50
Tub Top Cradle	2082	25.00
U-Clamp	2085	.75
Screw (U-Clamp)	2086	.14
Bolt	2087	.39
Hinge Weldment (on side of trailer)	2088	7.75
Front Motor Gear Box	2089	300.00
Rear Motor Gear Box	2090	300.00
Female Socket (vertical)	2091	15.00
Female Socket (horizontal)	2092	15.00
Female Mounting Bracket (front only)	2093	9.00
Tarp Mounting Bracket (Universal)	2094	175.00
Pigtail vertical/horizontal electrical cord	2095	98.10
Hockey Stick	2096	14.00
Hockey Stick back plate	2097	7.00
Hockey Stick washer	2098	6.00
Female Socket boot cover	2099	6.00
Rocker Switch with mounting bracket	2100	21.00
Solenoid for Switch	2101	91.00
50 amp. breaker	2102	9.00
Power Cord Switch for Kit	2103	\$5/ lin. ft.

Troubleshooting

Q. When I lock down my tarp the back wants to get stuck on the hockey stick.

A. This is caused by the front being heavier than the back arm assembly due to the motor being on it. To correct this problem, adjust the hockey stick up, then try to get it in the right stop. You can do this by tapping the hockey stick with a hammer for smaller adjustments, then once in place re-tighten the bolts to keep them from moving anymore.

Q. The front of the tarp will go under the side rail and the back will clear the hockey stick.

A. This is caused because of the weight of the motor on the front. Gravity will naturally pull the front down more than the back. The first thing is to do is to check to see if your tube is long enough that the roll tube will hit the hockey stick. If it wants to hit the shaft the tube is too short. If the tube is long enough then over on the front face of the rear tension box there is a 3/8" nut lower the tarp down so that all the tension is off the boxes. Then take out that 3/8" bolt and nut with a crescent wrench, turn that black arm so it will go down to the bottom setting. This will take of tension on the tarp and allow it to go under the side rail.

Q. When I open the tarp to the open position, the front won't go over as far as the back.

A. The first thing to do is make sure that the tarp is rolling up as even as it can. If it is, then roll it back over to the closed position and adjust the U - clamps. Take out only the two front U - clamps and turn the tarp so that the old holes where the screw went through are going to be at the top of the U - clamp. You will be turning the tarp up. This will ease the tension and will give more tarp to roll up and will bring the front over the rest of the way.



Sioux City Tarp
5201 Harbor Drive
Sioux City, IA 51111
Ph: 712-258-6939

Reference Photographs

